

# BUFFALO ROAD BLOCKER



Buffalo Series Road Blocker is designed for long life operation specially to provide passing safety and control..

Durability of product has proven by the crash test which realized with 7 tonnes vehicle incoming 88 kmh speed.

Standard production length is variable from 2 M to 6 M, and movable part height can be change from 50 CM to 100 CM.

Buffalo series road blocker designed and produced as fully compliant for all kind of access control systems..

Road blocker main structure has built from S235JR quality steels, all hydraulic parts like unit, valves, locks are from BOSCH - Rexroth brand.

## General Informations and Standards

- ▶ TMAG Control Card
- ▶ 2-3 M single piston, 4-5-6 M double piston
- ▶ 4-6 sec operation speed
- ▶ 3/8R2 Hydraulic hoses 330 bar withstand
- ▶ Crash test certificated
- ▶ 100% heavy duty cycle
- ▶ Fully compliant for access control systems
- ▶ Safety Photocell and support
- ▶ WR100 Desktop button system
- ▶ High performance working
- ▶ Fully safe and reliable operation
- ▶ Remote control and receiver system
- ▶ 2 years warranty



## Product Details

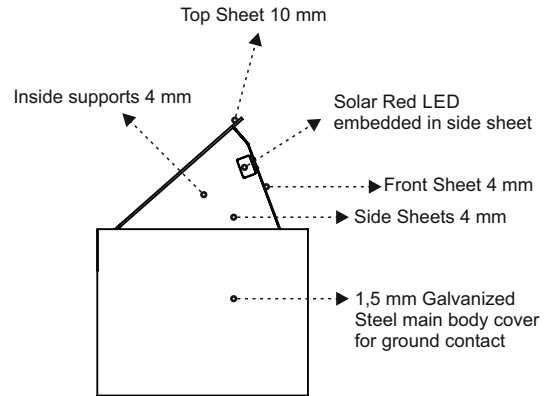
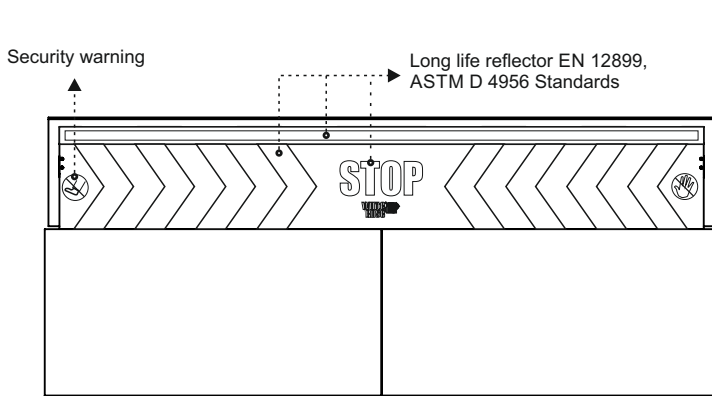

## Dimensions

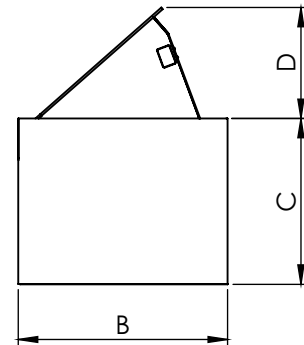
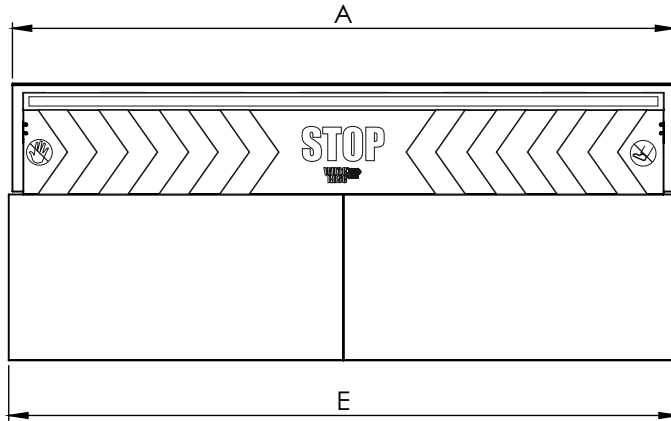

		LENGTH																								
		2 M					3 M					4 M					5 M					6 M				
		A	B	C	D	E	A	B	C	D	E	A	B	C	D	E	A	B	C	D	E	A	B	C	D	E
RISING	50 cm	945	730	500		945	730	500		945	730	500		945	730	500		945	730	500		945	730	500		
	60 cm	1045	850	600		1045	850	600		1045	850	600		1045	850	600		1045	850	600		1045	850	600		
	70 cm	1145	950	700		1145	950	700		1145	950	700		1145	950	700		1145	950	700		1145	950	700		
	80 cm	1245	1050	800		1245	1050	800		1245	1050	800		1245	1050	800		1245	1050	800		1245	1050	800		
	90 cm	1345	1150	900		1345	1150	900		1345	1150	900		1345	1150	900		1345	1150	900		1345	1150	900		
	100 cm	1445	1250	1000		1445	1250	1000		1445	1250	1000		1445	1250	1000		1445	1250	1000		1445	1250	1000		
	110 cm	1545	1350	1100		1545	1350	1100		1545	1350	1100		1545	1350	1100		1545	1350	1100		1545	1350	1100		
	120 cm	1645	1450	1200		1645	1450	1200		1645	1450	1200		1645	1450	1200		1645	1450	1200		1645	1450	1200		

Forceful Series Road Blocker destroyed the 7000 kg truck, which is incoming 88 kmh speed, as completely unusable state and didn't allow passing, therefore it has proved 100% Safety by the K12 crash test certification.



## Technical Datasheet

Type	BUFFALO SERIES				
Model	WBF200	WBF300	WBF400	WBF500	WBF600
Length	2 mt	3 mt	4 mt	5 mt	6 mt
Movable Part	S235JR quality sheet – Upper sheet 10mm / Front sheet 4mm / Side sheet 4mm / Inner enforcements 4mm				
Working System	Hydraulic				
Power Supply	380 V 3 Phases 50/60 Hz				
Control Card	T-MAG Control Card				
Current	3,8 A		5,15 A		
Motor Power	1,5 KW		2,2 KW		
IP Standard	54				
Number of piston	Single Piston		Double Pistons		
Opening Time	4-6 sec				
Duty Cycle	100%				
Lift power	900 Kg		1800 Kg		
Limit Switch Type	Adjustable engine working period				
Working Pressure Min	20 Bar				
Working Pressure Max	75 Bar				
Manual Opening	None				
Manual Closing	Optional Handle Pump				
Hydraulic Oil Type	32 or 46 number hydraulic oil				
Warning Light	Power Solar Red Led assembled on side ironsheets				
Hydraulic Hose	3/8 R2 330 Bar				
Working Temperature	-20°C min +70°C max				
Accumulator Supply	None				
Emergency Close	Optional				
Water Drainage Pump	Optional				
Crash Test	Test Certificate				

## Optional Extras

- ▶ Oil Heater
- ▶ Oil Cooler
- ▶ Emergency Fast Operation (1 sec)
- ▶ Manual Hand Pump
- ▶ PLC Control Panel
- ▶ PLC Control Screen
- ▶ Traffic Lights (red-green)
- ▶ Traffic Lights Post
- ▶ Automatic Water Pump
- ▶ Loop Dedector
- ▶ Checkered Plate
- ▶ Hot Dip Galvanization

### ADRESS

Organize Sanayi Bölgesi  
9. Cad. No. 1 KARAMAN, TR

T: 0 338 224 13 60

F: 0 338 224 14 46

M: whiterose@whiterose.com.tr

W: www.whiterose.com.tr